

MFSC

5000W~6000W

Single Module CW Fiber Laser



Product Feature

Premium components, superior performance and longer lifetime



Up to 6KW Output From CW Single Module Series

Better beam quality vs. multi module lasers
Greatly improved efficiency



Excellent Material Processing Performance

High speed in thin sheet cutting
Strong capability in thick material processing



Compact Design, Maintenance Free

Highly integrated system with modular design
Easy maintenance significantly reduce TCO



Smaller Size with Higher Stability

>60% reduction in volume
Higher flexibility when integrated in to system



High Level Vertical Integration

All key components are designed and produced in house
Strict quality control, high consistency and reliability

MAX PHOTONICS

MFSC 5000W~6000W Fiber Laser Specifications

Models	MFSC-5000W	MFSC-6000W
OPTICAL SPECIFICATIONS		
Nominal Power	5000W	6000W
Mode of Operation	CW/Modulated	
Polarization	Random	
Power Tunability	10 to 100%	
Wavelength	1080 ± 10 nm	
Power Stability	±1 %	
Laser Beam Quality, BPP	2.8 to 3.6 mm x mrad (100µm QBH)	
Modulation Frequency	≤ 5kHz	
Preview Red Light Power	200 µW	
FIBER DELIVERY SYSTEM		
Interface	QBH(LOC)	
Length	20m standard, other lengths optional	
Diameter	100(150/200) µm	
Bending Radius	200 mm	
ELECTRICAL RATINGS		
Supply Voltage	400VAC (-15% to +10%) 3-phase	
OTHER SPECIFICATIONS		
Operating Temperature	+10 to +40°C	
Storage Temperature	-10 to +60°C	
Humidity	10 to 85%	
Cooling Method	Water Cooling	
Cooling Medium	Distilled water/ Glycol Antifreeze	
Dimension	640×1173×1102 mm	
Weight	240(±20) kg	

Mechanical Specifications (mm)

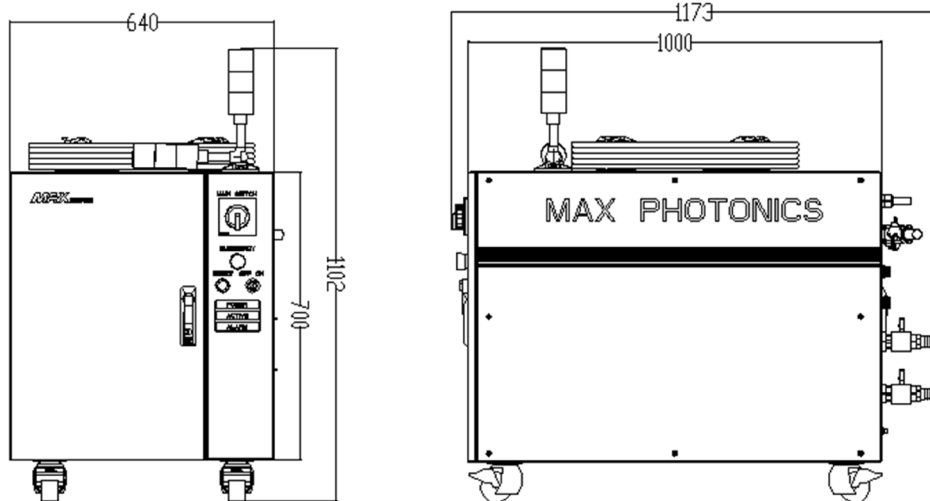

Maxphotonics Co.,Ltd.

Address: Maxphotonics Industrial Park, 3rd Furong Road,
Furong Industrial Area, Shajing, Bao'an, Shenzhen, China.518125
E-Mail: sales@maxphotonics.com <http://en.maxphotonics.com>

MAX PHOTONICS